

# Installation manual

## M Motorized Ceilingmount Pro SD

EAN: 7350073739592

en	Installation manual
ar	تثبيت السقف لـ م
cz	Instalační manuál
da	Installationsmanual
de	Installationsanleitung
ee	Paigaldusjuhend
el	Οδηγίες εγκατάστασης
es	Manual de instalación
fi	Asennusohje
fr	Installation Manuel
he	הנחיה לריתוק
hu	Szerelési kézikönyv
it	Manuale di installazione
jp	取り付け説明書
kr	설치 설명서
li	Montavimo instrukcija
lt	Uzstādīšanas rokasgrāmata
nl	Installatie handleiding
no	Installasjonshåndbok
pl	Instrukcja instalacji
pt	Manual de instalação
ro	Manual de instalare
ru	Инструкция по установке
sk	Inštaláčny manuál
sl	Navodila za montažo
sv	Installationsmanual
tr	Montaj kılavuzu
zh	安装手册



**en** **IMPORTANT!**  
Your Plasma, LCD, TV, Projector, Projector Screen or other HiFi equipment represents a considerable value.  
If screws are included they may not be suitable for the material of your wall, ceiling or floor. Replace the screws with suitable ones if needed.  
In case you are unsure regarding any aspects of the mounting of this product please Consult a professional.

**ar** **أهم!**  
إن شاشة البلازما أو LCD أو التلفاز أو جهاز العرض أو شاشة جهاز العرض أو أجهزة هاي فاي الأخرى أجهزة ذات قيمة عالية.  
إذا كانت البراغي مرفقة، فقد لا تكون مناسبة لمادة الجدار أو السقف أو الأرضية.  
تبدل بالبراغي أخرى مناسبة إذا لزم الأمر.  
في حالة عدم العلامه بأي جزئية من جزئيات تركيب هذا المنتج، يرجى استشارة فني متخصص.

**cz** **DŮLEŽITĚ!**  
Váš plazmový nebo LCD televizor, projektor, plátno a další elektrotechnické vybavení je vysoce hodnotné.  
Pokud jsou součástí balení produktu šrouby, zkontrolujte, zda jsou vhodné pro upevnění ke stěně, stropu nebo podlaze v místě instalace.  
V případě, že nebudou přibalené šrouby vyhovovat, vyměňte je.  
Pokud budete mít při montáži tohoto produktu potíže, obraťte se na zkušeného odborníka.

**da** **VIGTIGT!**  
Din plasmaskærm, LCD-skærm, tv, projektor, projektorskærm eller andet HiFi-udstyr repræsenterer en betydelig værdi. Hvis der medfølger skruer, passer de muligvis ikke til materialet i væggen, loftet eller gulvet. Udskift skruerne med passende skruer, hvis det er nødvendigt.  
Hvis du er i tvivl om noget i forbindelse med monteringen af produktet, skal du kontakte en ekspert.

**nl** **BELANGRIJK!**  
Uw Plasma, LCD TV, Projector, Projector scherm of andere HiFi-apparatuur vertegenwoordigt een aanzienlijke waarde.  
Het kan zijn dat de bijgeleverde schroeven niet geschikt zijn voor uw toepassing. In dat geval dient u ze te vervangen door schroeven die wel geschikt zijn. Twijfelt u, raadpleeg dan een professional.

**ee** **TÄHTIS!**  
Teie teler, projektor, projektori ekraan või muu HiFi seade on suure väärtusega.  
Kui kinnitusel on komplektis paigalduskruvid, siis ei pruugi need sobida Teie seinale, lae või põranda materjaliga. Vajadusel vahetage kruvid sobivate vastu.  
Kui Te ei ole seadme paigaldamise detailides kindel, siis konsulteerige spetsialistiga.

**de** **ACHTUNG!**  
Ihr Plasma-, LCD-, TV-Gerät, Ihr Projektor, Ihre Leinwand oder sonstige HiFi-Ausrüstung stellen einen beträchtlichen Wert dar. Die möglicherweise im Lieferumfang enthaltenen Schrauben sind unter Umständen nicht für das Material ihrer Wände, Decken oder Böden geeignet. Ersetzen Sie sie bei Bedarf durch geeignete Schrauben.  
Wenn Sie bezüglich der Montage des Produkts unsicher sind, wenden Sie sich an einen Fachman

**el** **ΣΗΜΑΝΤΙΚΟ!**  
Οι τηλεοράσεις Plasma, LCD, α κανονικές τηλεοράσεις, οι οθόνες προβολέων ή άλλες συσκευές HiFi έχουν μία αξιολογούμενη αξία. Αν περιλαμβάνονται βίδες ή σπασ ή μην είναι κατάλληλες για το υλικό του τοίχου, του ταβανιού ή του πτωμόστους σας. Αντικαταστήστε τις βίδες με κατάλληλες αν είναι απαραίτητο.  
Στην περίπτωση που δεν είστε σίγουροι για κάποιες ζητήματα σχετικά με την προσάρτηση αυτού του προϊόντος, παρακαλούμε συμβουλευτείτε έναν ειδικό.

**es** **IMPORTANTE!**  
Los equipos de plasma o LCD, los televisores, proyectores y pantallas de proyección, así como otros equipos de alta fidelidad suponen una inversión considerable. Si incluyen tornillos, puede que no sean adecuados para el material del que estén formados la pared, el techo o el suelo. Sustituya estos tornillos por otros más adecuados si es preciso.  
Si no está seguro sobre cualquier aspecto del montaje de este producto, consulte a un profesional.

**fi** **TÄRKEÄÄ!**  
Plasma- tai nestekidenäyttöjen, televisioiden, projektorien ja niiden valkokankaiden sekä muiden hiifi-laitteiden arvo on huomattava. Laitteen mukana toimitettavat ruuvit eivät välttämättä sovellu seinien, katon tai lattian materiaaliin. Korvaa ne tarvittaessa sopivilla ruuveilla.  
Mikäli olet epävarma mistä tahansa tämän tuotteen kiinnittämisessä liittyvästä seikasta, ota yhteyttä asiantuntijaan.

**fr** **IMPORTANT!**  
Vos écrans plasma, LCD, télévisions, projecteurs, écrans de projection ou autre matériel Hi Fi ont une valeur considérable. Les vis fournies peuvent ne pas être compatibles à la nature de vos murs, plafonds et sols. Remplacez-les par des vis adaptées.  
Si vous avez des doutes quant au montage de ce produit, veuillez consulter un professionnel.

**hu** **FONTOS!**  
Plazma, LCD TV-d, projektorod, vetítővásznad vagy egyéb műszaki berendezéseid tekintélyes értéket képvisel. Ha a csavarokat tartalmazza, akkor sem biztos, hogy alkalmas a berendezés, hogy falra, mennyezetre, vagy a padlóhoz rögzítsd. Cseréld ki a csavarokat a megfelelőre, ha szükséges. Abban az esetben, ha nem biztos a termék beépítésével kapcsolatban, forduljon szakemberhez.

**it** **IMPORTANTE!**  
I vostri plasma, LCD, TV, proiettori, schermi di proiezione o altri apparecchi Hi-Fi rappresentano un notevole investimento. Le viti in dotazione potrebbero rivelarsi non adatte per il materiale della parete, del soffitto o del pavimento. Sostituitele quindi con viti più idonee in caso di necessità.  
Nel caso riscontriate problemi nel montaggio di questo prodotto, consultate un tecnico specializzato.

**jp** **重要!**  
あなたのプラズマ、LCDは、テレビ、プロジェクタ、プロジェクタースクリーンまたは他のハイファイ機器はかなりの値を表します。  
ネジが含まれている場合、彼らはあなたの壁、天井や床の材質に適していないかもしれせん。  
必要に応じて適切なものでネジを取り付けます。  
ケースでは、本製品の取り付けのいずれかの側面に不明な点があるプロに相談してください。

**no** **VIKTIG!**  
Din plasma, LCD, TV, projektor, projektorskjerm eller annet HiFi-utstyr har betydelig verdi. Din skruer følger med, er det ikke sikkert at de passer til materialet i veggen, taket eller gulvet. Bytt skruene i skruer som er egnet om nødvendig.  
Hvis du er usikker når det gjelder monteringen av dette produktet, må du kontakte en profesjonell.

**pl** **UWAGA!**  
Monitor plazmowy, LCD, telewizor, projektor, ekran projekcyjny lub inny sprzęt HiFi stanowi znaczną wartość. Jeśli dołączono do niego śruby mocujące, mogą one nie być odpowiednie do materiału, z którego wykonane są dane ściany, sufit lub podłoga. W razie potrzeby należy je zastąpić odpowiednimi śrubami.  
W razie jakichkolwiek wątpliwości dotyczących montowania tego urządzenia należy zasięgnąć porady u specjalisty.

**pt** **IMPORTANTE!**  
O seu Plasma, LCD, TV, projetor, tela de projeção ou outro equipamento de HiFi representa um valor considerável.  
Se os parafusos estão incluídos eles podem não ser adequados para o material da sua parede, teto ou chão.  
Substitua os parafusos com os adequados, se necessário.  
Em caso de dúvida sobre quaisquer aspectos da montagem deste produto, consulte um profissional.

**li** **SVARİĞI!**  
Jūsu Plasma, LCD, TV, projektor, projektora ekrāns vai cita HiFi iekārta veido ievērojamu vērtību.  
Iekārtās skrūves var būt nepiemērotas jūsu sienai, griestu vai grīdas materiāliem. Nomainiet skrūves ar piemērotām skrūvēm, ja nepieciešams.  
Gadījumā, ja jūs neesat pārliecināts par jebkuriem šo produktu montāžas un stiprinājumu aspektiem, lūdzu, konsultējieties ar speciālistu

**lt** **SVARBU!**  
Jūsų plazminis TV, LCD, LED televizorius, projektorius, projektoriaus ekranas ar kita HiFi įranga turi didelę vertę.  
Jei varžtai yra komplekte, jie gali netikti pas Jus panaudotoms sienų, lubų ar grindų medžiagoms.  
Pakeiskite varžtus į tinkamus, jei reikia.  
Jei nesate tikras dėl bet kurio šio produkto montavimo aspekto - prašome kreiptis į profesionalus.

**ro** **IMPORTANT!**  
Plasma ta, LCD, TV, projector, ecran de proiectie sau alte echipamente HiFi reprezintă o valoare considerabilă.  
În cazul în care șuruburile sunt incluse ele nu pot fi potrivite pentru materialul peretelui dvs., tavan sau podea.  
Remontați șuruburile cu cele adecvate, dacă este necesar.  
În cazul în care nu sunteți sigur cu privire la orice aspecte ale montării acestui produs vă rugăm să consultați un profesionist.

**ru** **ВНИМАНИЕ!**  
Каким бы оборудованием HiFi вы ни пользовались, будь то плазменный, ЖК или стандартный телевизор, проектор или проекционный экран, - все они представляют значительную ценность. Не всегда крепления, прилагаемые в комплекте, подходят к материалу ваших стен, потолка или пола. При необходимости замените их на более подходящие.  
Если у вас есть какие-либо сомнения относительно того, как крепить данный продукт, пожалуйста, проконсультируйтесь у квалифицированного специалиста.

**sv** **VIKTIG!**  
Din plasmaskärm, LCD-skärm, TV, projektor, projektorskärm eller annan HiFi-utrustning representerar ett ansenligt värde. Om skruvar medföljer utrustningen är det inte säkert att de passar för materialet i väggen, taket eller golvet! Byt ut skruvarna mot lämpliga skruvar om så krävs. Kontakta en expert om du är osäker på något i samband med monteringen av produkten.

**sk** **DŮLEŽITĚ!**  
Váš plazmový alebo LCD televizor, projektor, plátno a ďalšie elektrotechnické vybavenie je vysoko hodnotné.  
Pokiaľ sú súčasťou balenia produktu skrutky, skontrolujte, či sú vhodné pre upevnenie k stene, stropu alebo podlahe v mieste inštalácie.  
V prípade, že nebudú pribalené skrutky vyhovovať, vymeňte ich.  
Pokiaľ budete mať pri montáži produktu potiaže, obráťte sa na skúseného odborníka

**sl** **POMEMBNO!**  
Vaš Plasma, LCD, TV, projektor, projekcijsko platno ali drugo HiFi oprema predstavlja pomembno vrednost.  
Če so vključeni vijaki ne smejo biti primerni za material svojega steno, strop ali tla.  
Ponovno namestite vijake z ustreznimi tiste, če je potrebno.  
V primeru, da ste prepričani o vseh vidikih vgradnje tega izdelka se obrnite na strokovnjaka.

**tr** **ÖNEMLİ!**  
Plazma, LCD, TV, Projektör, Projektör Ekranınız veya diğer HiFi cihazınız son derece değerlidir. Birlikte verilen vidalar duvar, tavan veya döşeme teçhizatınıza uygun olmayabilir. Gerektiğinde vidaları uygun olanlarla değiştirin.  
Bu ürünün monte şekilleri ile ilgili sorunlarınız olmasa halinde bir uzmandan yardım alın.

**zh** **重要提示!**  
您的等离子、LCD、TV、投影机、投影机屏幕或其它HiFi设备都有着不菲的价值。如果附带有螺钉它们可能不适合您的墙壁、天花板或地板。如果需要请将螺钉更换为适当的型号。  
如果对本产品安装的任何方面有疑问请咨询专业人员。



**Warning!**

Always check the depth of the holes before starting an installation.

**تحذير**

افحص دائما عمق الثقوب قبل أن تبدأ في عملية التركيب.

**ADVARSEL!**

Kontroller alltid hullernes dybde, før du går i gang med en installasjon.

**WARNUNG!**

Vor Beginn des Einbaus immer die Tiefe der Bohrungen überprüfen.

**ΠΡΟΕΙΔΟΠΟΙΗΣΗ!**

Ελέγχετε πάντοτε το βάθος των οπών προτού ξεκινήσετε την εγκατάσταση.

**WARNING!**

Always check the depth of the holes before starting an installation.

**¡AVISO!**

Controla siempre la profundidad de los agujeros antes de iniciar una instalación.

**VAROITUS!**

Selvitä reikien syvyyks ennen asentamisen aloittamista.

**ATTENTION !**

Vérifiez toujours la profondeur des trous avant de commencer l'installation.

**ATTENZIONE!**

Verificare sempre la profondità dei fori prima dell'installazione.

**Varování!**

Před začátkem instalace vždy zkontrolujte potřebnou hloubku všech otvorů.

**ADVARSEL!**

Sjekk alltid hvor dype hullene er før du begynner å montere.

**OSTRZEŻENIE!**

Przed przystąpieniem do montażu należy koniecznie sprawdzić głębokość otworów.

**ПРЕДУПРЕЖДЕНИЕ!**

Перед установкой всегда проверяйте глубину отверстий.

**WARNING!**

Kontrollera alltid hålens djup innan en installation påbörjas.

**UYARI!**

Montaja başlamadan önce daima deliklerin derinliğini kontrol edin.

**警告!**

请始终在安装前检查孔洞的深度。

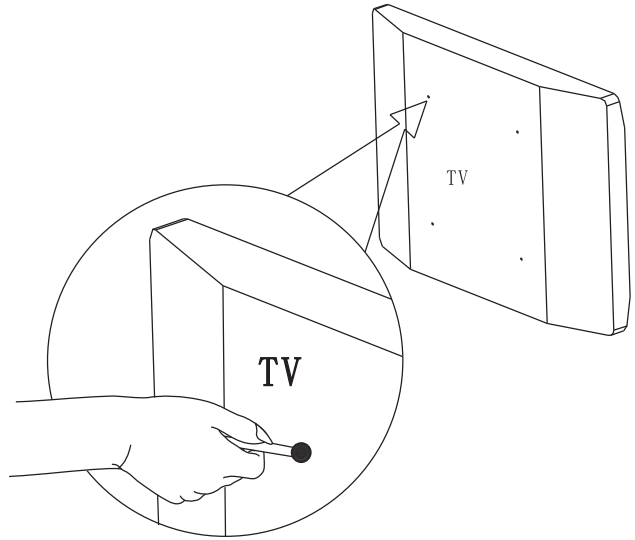

**WARRANTY CARD**

MULTIBRACKETS.COM

**MULTIBRACKETS™ Limited Warranty**

Multibrackets warrants its products to be free of defects in material and workmanship for the product's Warranty Period. The Warranty Period commences on the original purchase date of the product.

All Multibrackets products are covered by a limited product warranty:

- FIVE (5) years for metal video monitor mounts; all racks and non-electrical rack accessories
- TWO (2) years for gaslifts and sit-stand workstations
- ONE (1) year for all motorized and/or automated products, plastic speaker mounts; all speaker stands; all furniture; all wood (MDF) accessories

For warranty claims made during the Warranty Period, MULTIBRACKETS will replace any defective product part free of charge. Should a part on your Multibrackets product fail, please create an RMA case on [www.multibrackets.com/support](http://www.multibrackets.com/support) to make a warranty claim. We will await your documentation and then discuss the problem with you and once we confirm the product is under warranty, we will ship replacement parts to you. This Limited Warranty does not cover the costs of removing and replacing defective parts from your Multibrackets product. So, if your problem requires a repair technician, you must pay any labor charges.







This Limited Warranty extends only to the original purchaser of the product and is automatically void if your Multibrackets product is modified in any way, improperly installed, taxed beyond its stated weight capacity or otherwise misused or abused. All Multibrackets products are intended for indoor use only and any

outdoor use voids this Limited Warranty. The Limited Warranty for wall and ceiling mounts is void if the mount is moved from its initial installation. To the maximum extent permitted by applicable law, Multibrackets disclaims any other warranties, express or implied, including warranties of fitness for a particular purpose and warranties of merchantability. Multibrackets will not be liable for any damages whatsoever arising out of the use or inability to use its products, even if Multibrackets has been advised of the possibility of such damages. To the maximum extent permitted by applicable law, Multibrackets disclaims any responsibility for incidental or consequential damages.

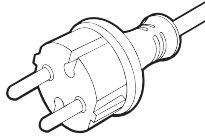
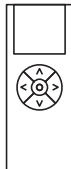
Multibrackets™ Stockholm Sweden 2016. [www.multibrackets.com](http://www.multibrackets.com)

The content of this manual is subject to change without further notice. The latest version of this manual can be found online under the product name on the website: [www.multibrackets.com](http://www.multibrackets.com)

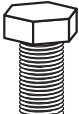
**Parts**

				
Power adapter (x1)	Power cable (x1)	Remote control (x1)	Short TV connection (x2)	Middle TV connection bracket (x2)
				
Long TV connection bracket (x2)	Small screw (x4)	Screws (x20)	M8 Screw nuts (x8)	Fixed install strip (x2)



## Product dimensions

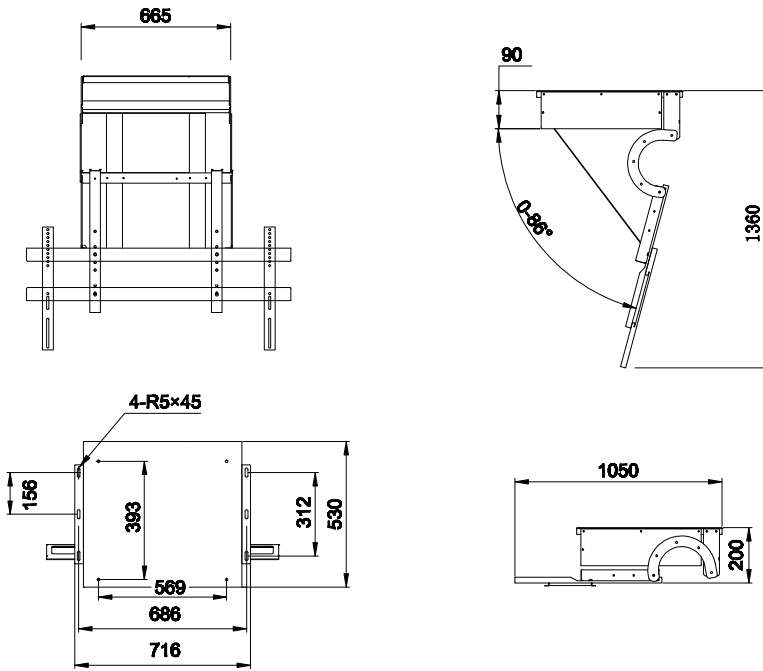

## Connectivity

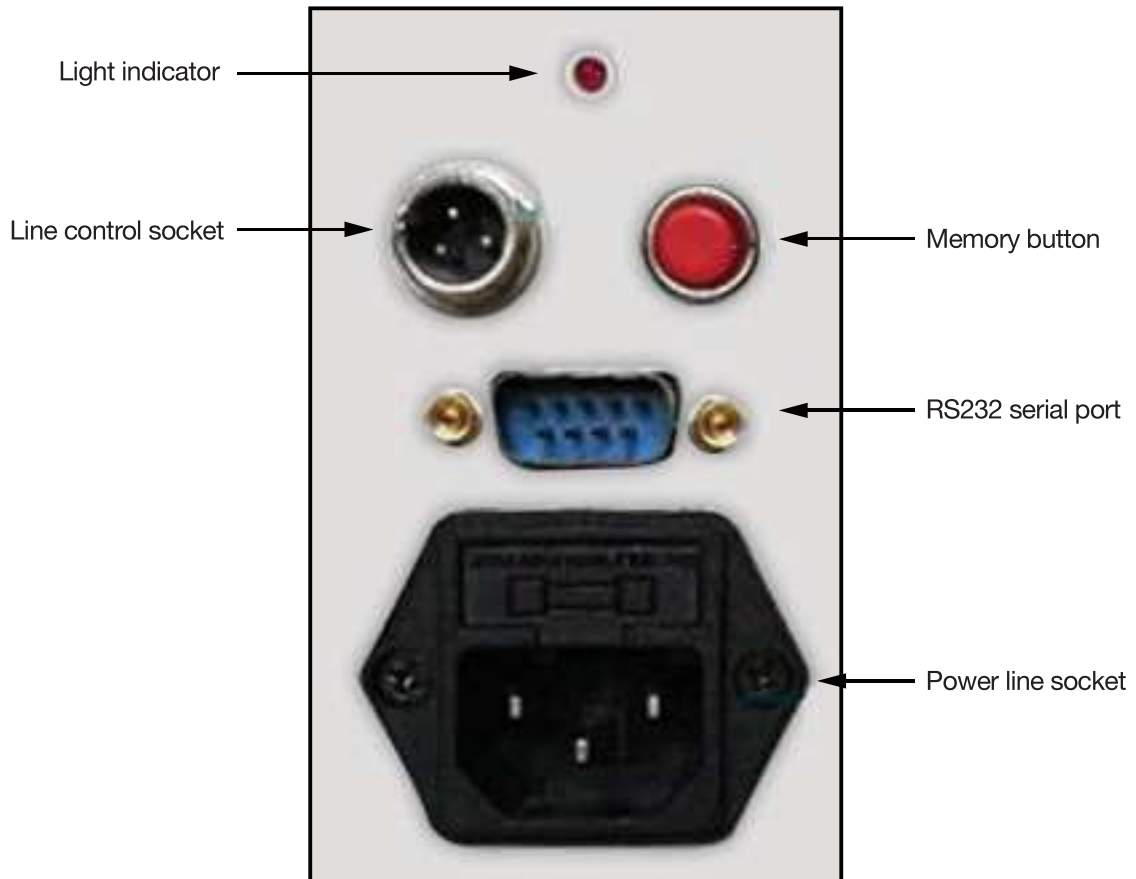

# Product installation

1. Always consult a professional installer when installing this item.
2. Make sure there is space for the display in the area where the screen is moved up into ceiling position. Inspect the area and that there is no obstruction by pipes or other objects stopping the screen from moving into position.
3. The ceiling opening size is generally required to be minimum equal to or greater than the size of the TV.
4. It is recommended to reserve an inspection port in the ceiling for easy maintenance.
5. **IMPORTANT:** During installation, there should be no people standing under the ceiling mount.

## Overview

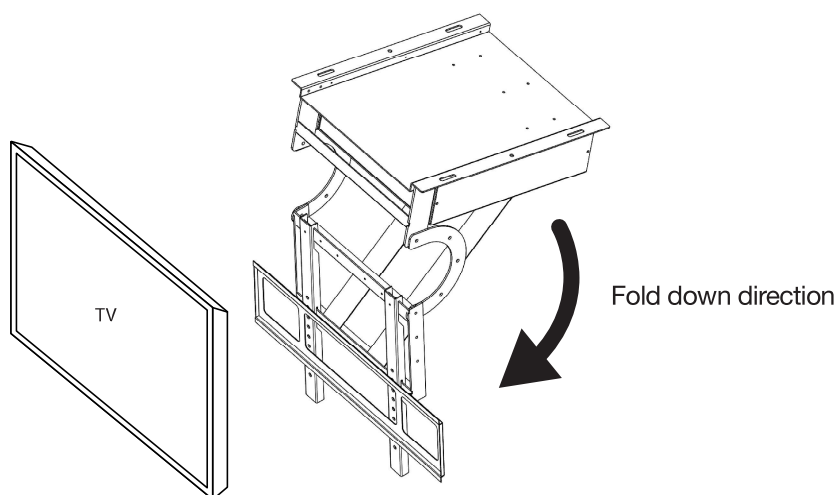
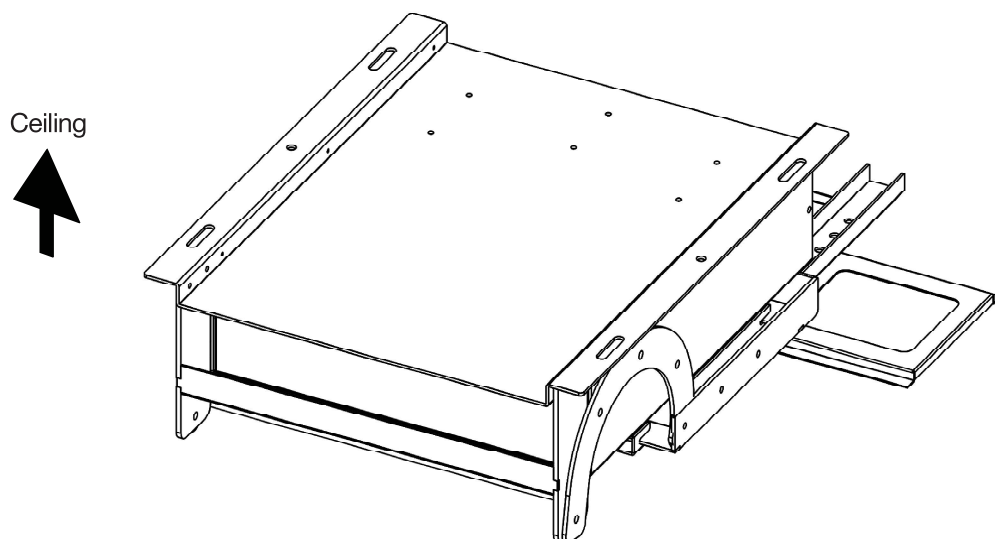

# Remote control

## Overview

### Buttons

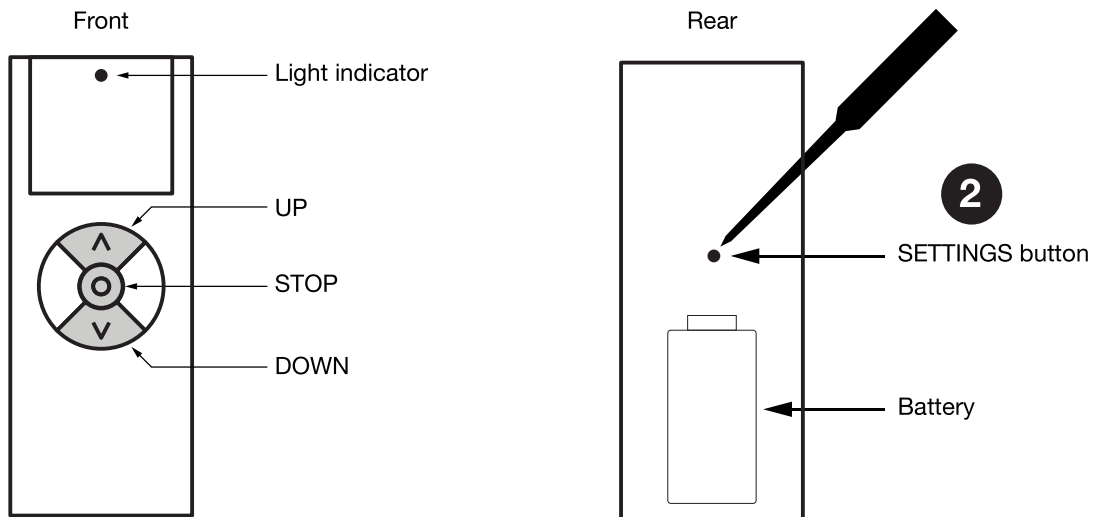

### Code matching mode for ceiling mount & remote control

1. First press the memory button on the panel, the indicator light starts to flash.
2. Release the memory button (1), press the settings button (2) on the back of the remote control and hold it down. The light indicator stops flashing. This indicates that the code has been successfully written and the remote control can be used. If not, repeat the above steps and try a few more times.

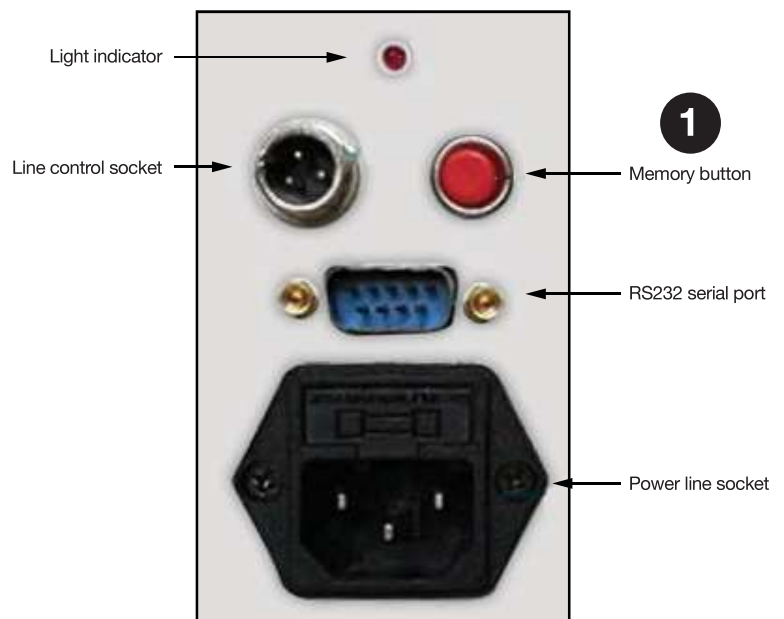



# Learn mode

## How to set upper and lower ideal position

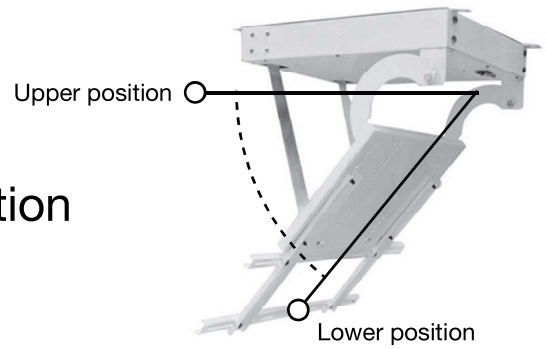

### Set the upper position

We recommend to set the upper position first, then the lower position. You can always restart the position setup process by unplugging the power and follow the steps below again.

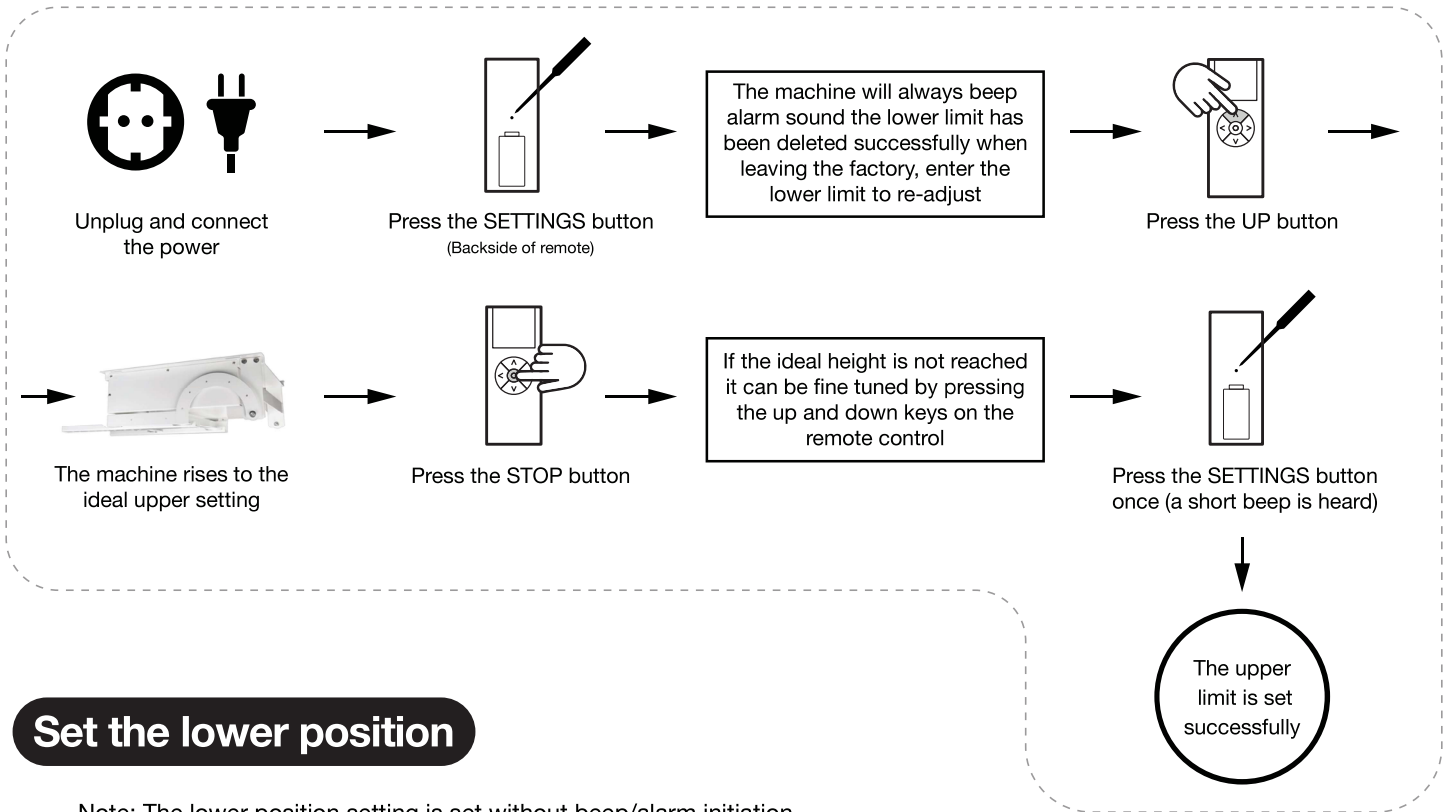

### Set the lower position

Note: The lower position setting is set without beep/alarm initiation.

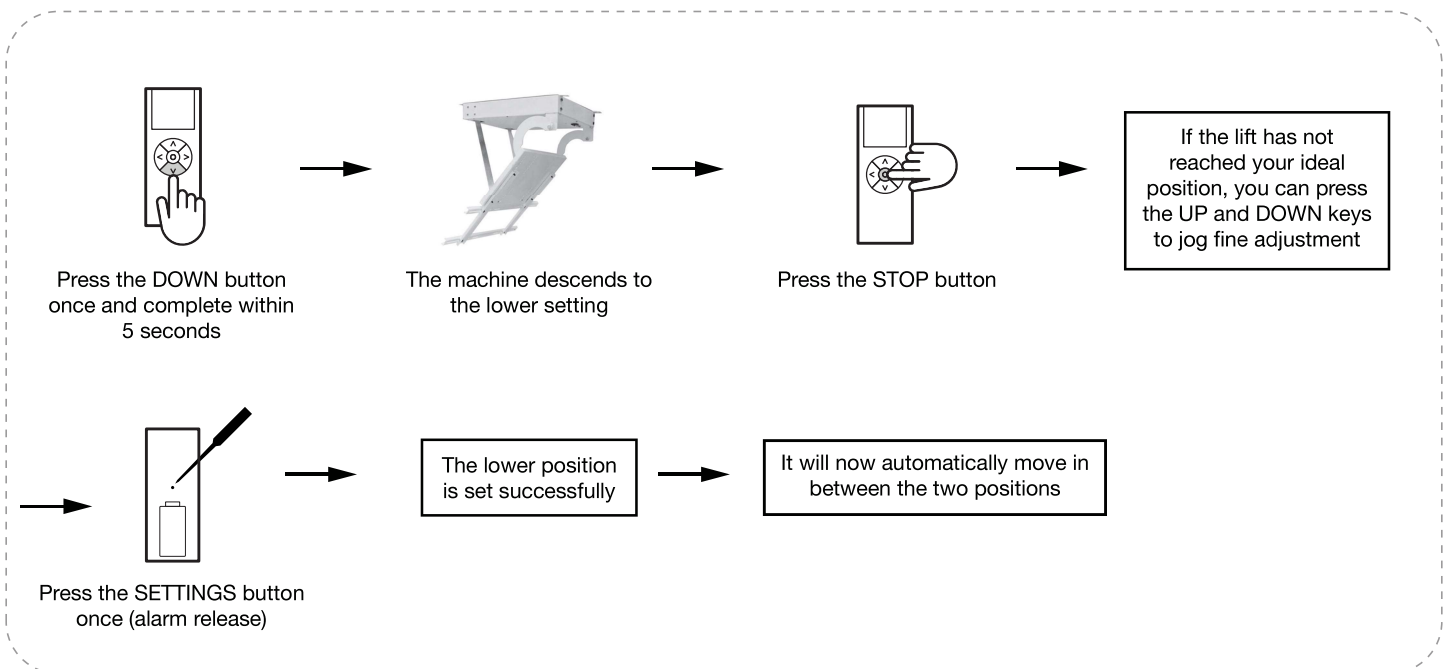

---

# RS 232 OVERVIEW

---

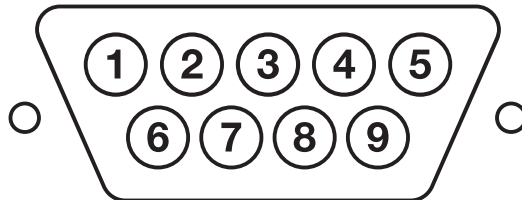

## **Center control wiring**

10 contact control (manual switch control, four -wire switch or three wire switch)  
DB9 Mother Head

6-feet public 7-feet up 8-feet down 9-feet stop  
6 and 7, go up  
6 and 8, go down  
6 and 9, stop

RS232 control (Machine Interface is DB9 mother head )

## **Serial Port setting:**

Baud rate 2400.  
Data bit :8  
check bit :N  
Stop bit :1

## **Machine connection**

2 feet (signal reception) 5 feet (signal ground wire )